

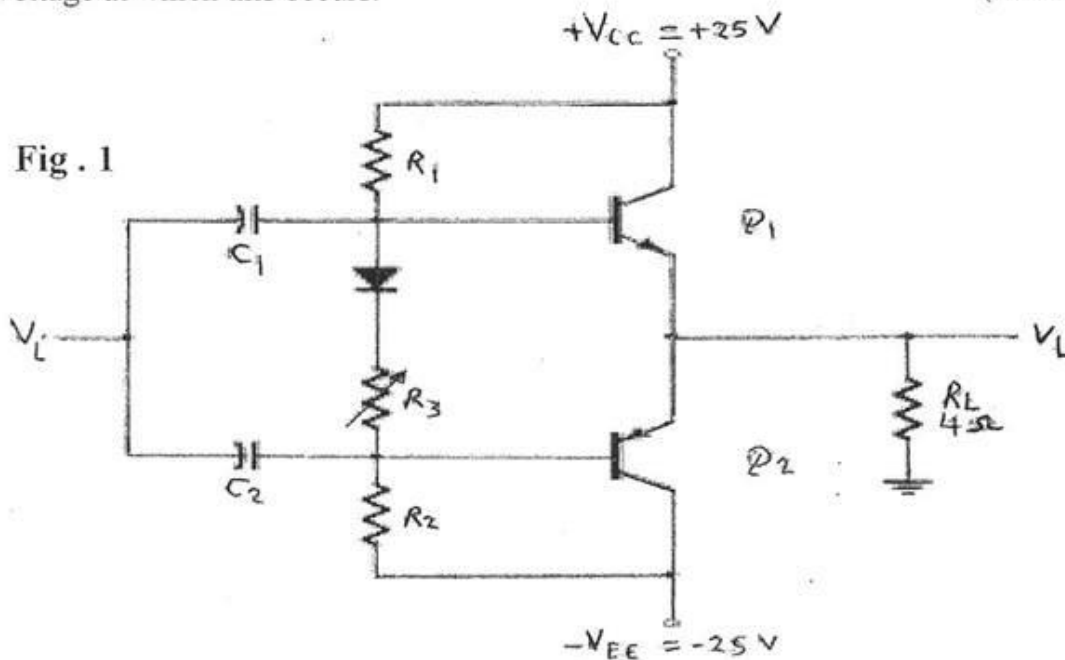

Solve the following questions:-

Question One (25 Mark)

- In a certain 2-stage amplifier, one stage has a lower critical frequencies of $f_{cl1}=850$ Hz, $f_{cl2}=200$ Hz, $f_{cl3}=3000$ Hz and upper critical frequencies of $f_{cu1}=850$ KHz, $f_{cu2}=100$ kHz. The other has a lower critical frequencies of $f_{cl4}=450$ Hz, $f_{cl5}=500$ Hz, $f_{cl6}=2000$ Hz and upper critical frequencies of $f_{cu3}=230$ KHz, $f_{cu4}=70$ kHz. Determine the bandwidth of each stage, and overall bandwidth of the 2-stage amplifier. (5 marks)
- For the circuit of Fig. 1., Calculate the input power, output power, power handled by each output transistor, the circuit efficiency for an input of 12 V rms, the maximum input power, maximum output power, input voltage for maximum power operation, and the power dissipated by the output transistors at this voltage. Also, find the maximum power dissipated by the output transistors and the input voltage at which this occurs. (15 mark)



- For harmonic distortion reading of $D_2 = 0.1$, $D_3 = 0.02$, and $D_4 = 0.01$, with $I_1 = 4$ A and $R_C = 8 \Omega$, calculate the total harmonic distortion, fundamental power component, and total power. (5 marks)

Question Two (30 Mark)

1. Plot the total gain and total phase frequency response of BJT amplifier shown in Fig. 2. And calculate the amplifier bandwidth (18 mark)

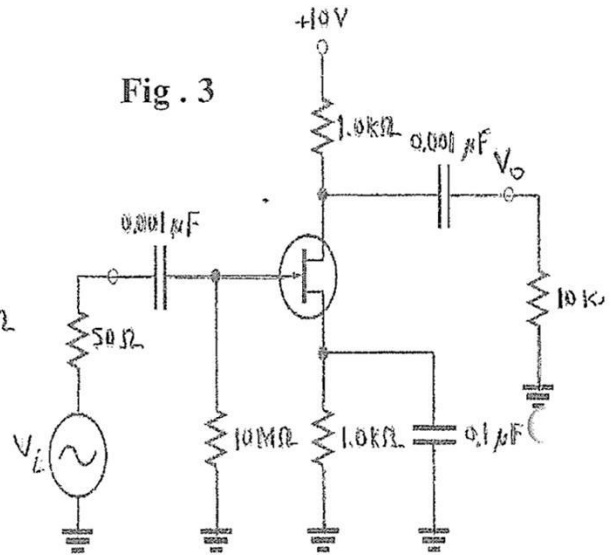
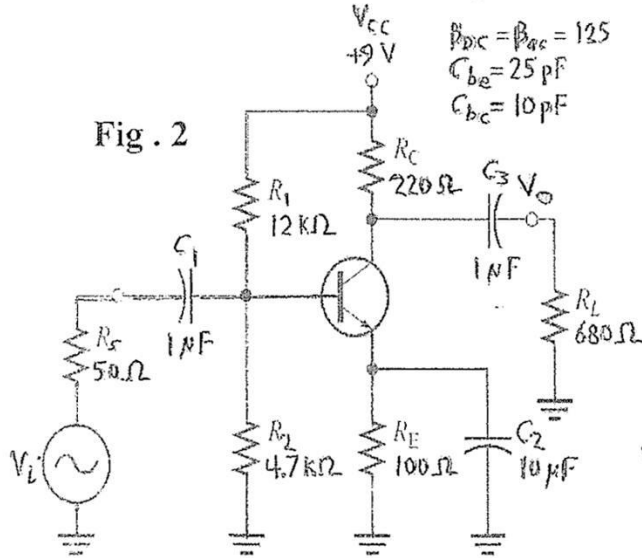

2. For the circuit of Fig. 3, Calculate the amplifier bandwidth if $C_{iss} = 10\text{ pF}$, $C_{rss} = 3\text{ pF}$, $I_{DSS} = 10\text{ mA}$, $I_{GSS} = 18\text{ nA}$, $V_{DS} = -10\text{ V}$, $V_{GS(OFF)} = -8\text{ V}$, $V_{GS} = -3.36\text{ V}$ (12 mark)

Question Three (15 Mark)

1. Determine the center frequency, maximum gain, and bandwidth for the filter in Fig.4. (7 mark)

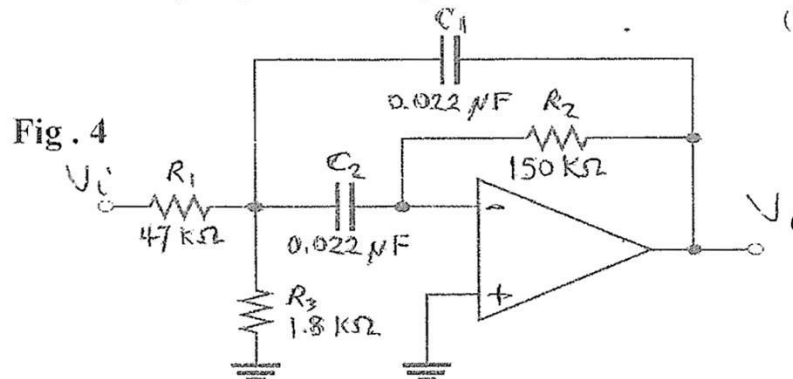

2. Design a band-stop filter with a center frequency of 60 Hz, and a quality factor of 10. (8 mark)

Best wishes of success
 Dr. Bedir yousif